

INLET: SPIGOT - SDR-35 PVC

Base Casting is ASTM A-48 Class 30 Cast Iron
(Various Contours available to fit 6.275" - 30.00" O.D. Mains)

PVC Adapter is an ASTM D3034, SDR-35 Spigot

Adapter cemented permanently in place with two-part urethane adhesive

Base of Saddle dip-coated in Waterbased Bituminous Coating

Strap is 24 ga. X 2.5" wide Type 304 Stainless Steel

Strap Pins are .75" dia. Type 303 Stainless Steel

T-Bolts are .375" - 16 Type 304 Stainless Steel

Nuts and Washers are Type 18-8 Stainless Steel

O-Ring is ASTM C-361-77 Tubular Polyisoprene

4" inlet requires a 4" dia. Tap in the Sewer Main

6" inlet requires a 6" dia. Tap in the Sewer Main
(Sewer Main must be at least 8" dia.)

Note: This Dwg. supercedes Dwg. No. R-3408-D2

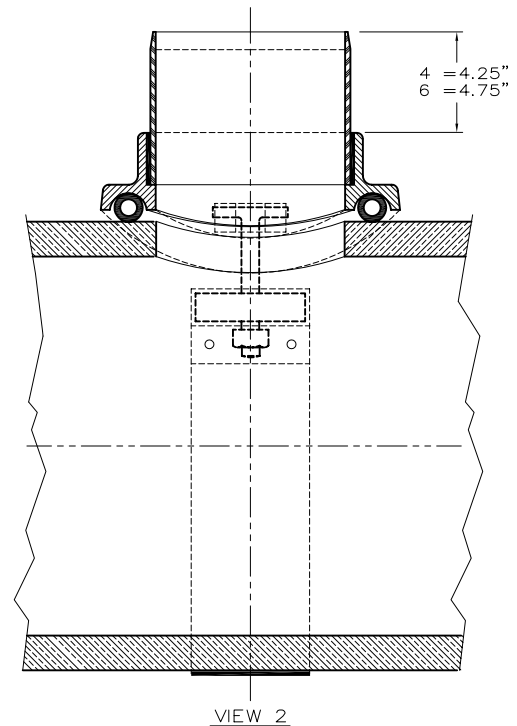
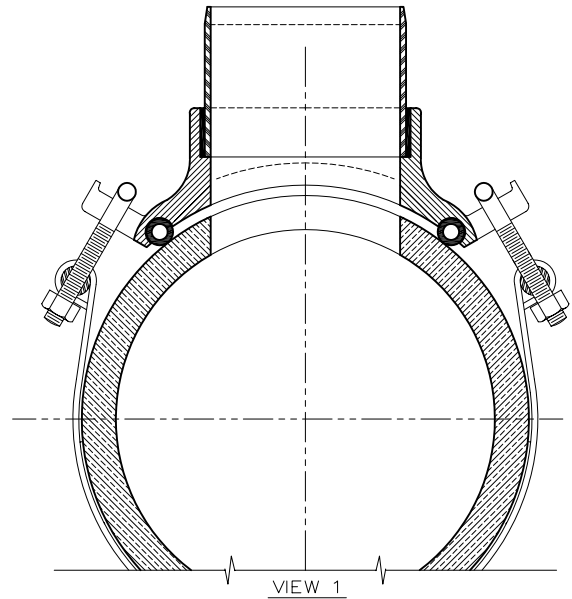

Type "PVC/U" Model "A" SEALTITE TEE[®] Gravity Sewer Saddle



THE GENERAL ENGINEERING COMPANY

P.O. Box 609, Frederick, MD 21705-0609
(301)663-9282 • (800)345-6454 • FAX: (301) 695-5612

DWG.NO.

U-A