

INLET: GASKETED BELL - XH C.I.

Base Casting and Inlet Bell Casting are
ASTM A-48 Class 30 Cast Iron
(Various Contours available to fit 6.275" - 30.00" O.D. Mains)

Base Casting has an ALIGNMENT FLANGE which
protrudes into the tapped hole to assure perfect alignment

Inlet Casting is XH Cast Iron Bell dimension

Bell is cemented permanently in place with two-part
urethane adhesive and SDR-35 PVC Sleeve

Entire Saddle is dip-coated in Waterbased
Bituminous Coating

Strap is 24 ga. X 2.5" wide Type 304 Stainless Steel

Strap Pins are .75" dia. Type 303 Stainless Steel

T-Bolts are .375" - 16 Type 304 Stainless Steel

Nuts and Washers are Type 18-8 Stainless Steel

O-Ring is ASTM C-361-77 Tubular Polyisoprene

4" inlet requires a 4.5" dia. Tap in the Sewer Main

6" inlet requires a 6.5" dia. Tap in the Sewer Main
(Sewer Main must be at least 8" dia.)

Note: This Dwg. supercedes Dwg. No. R-3432-D

Inlet Gasket is supplied with Saddle

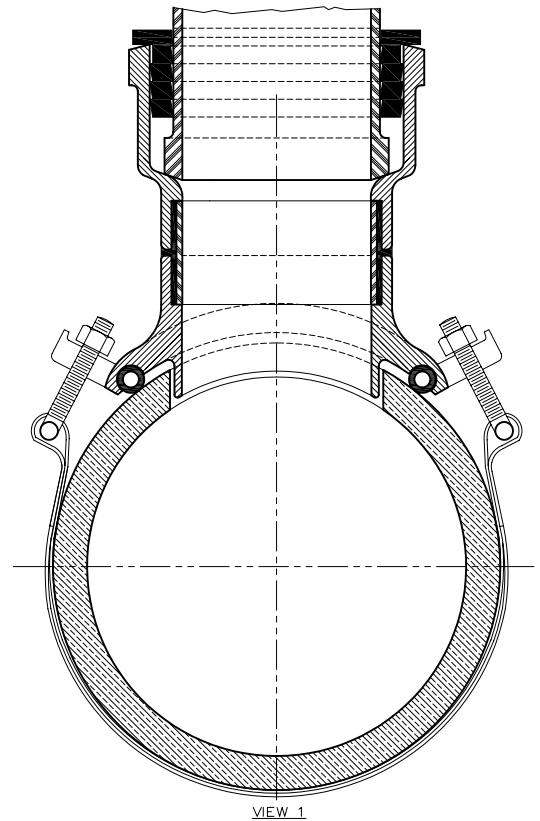

VIEW 1

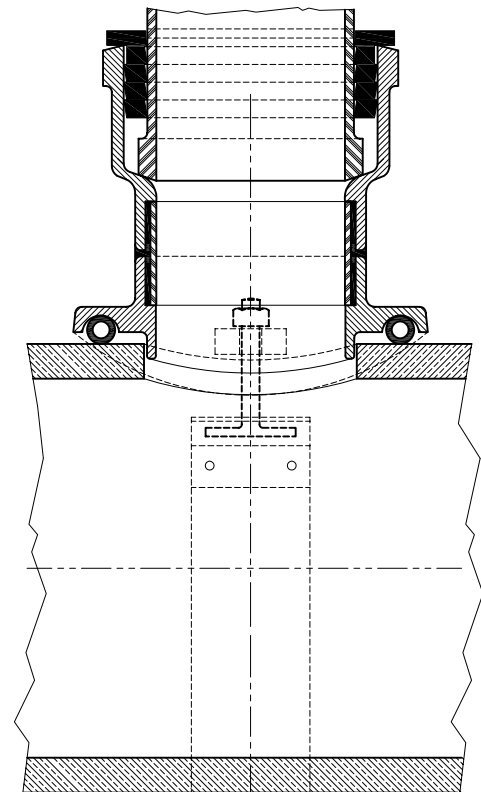

VIEW 2

Type "F" Model "EX"

SEALTITE TEE[®] Gravity Sewer Saddle (with Alignment Flange)



THE GENERAL ENGINEERING COMPANY

P.O. Box 609, Frederick, MD 21705-0609

(301)663-9282 • (800)345-6454 • FAX: (301) 695-5612

DWG.NO.

F-EX